

Beginning in the 1960s, IBM Research developed the virtual machine concept and helped launch the IBM System/360™, one of the first general-purpose mainframe computers, contributing breakthrough ideas for out-of-order execution that are still essential. In the following decades, Research contributed to the IBM System/370™, pioneered the Reduced Instruction Set Computer (RISC) along with superscalar architectures and compilers as part of the 801 Minicomputer project, and advanced innovative features that were incorporated in the IBM RISC System/6000™ and the IBM System/390™, to cite a few examples.

Research has also been in the forefront of pursuing the technical challenge of providing greater computing power than available in mainstream commercial systems. Supercomputer prototypes conceived and built at IBM Research include the Yorktown Simulation Engine, the GF11 supercomputer, and the RP3 Parallel Processor. In addition, Research was instrumental in launching IBM into commercial supercomputing — providing the high-speed interconnection network for IBM's first entry in its Scalable POWER (SP™) line of supercomputers in 1993. The famous Deep Blue was an SP system that paired each POWER™ processor with a Research-designed chess chip.

HIGH PERFORMANCE SYSTEMS

IBM's research in computer architecture and supercomputing focuses on attaining the highest performance systems in the industry. Since improvements in the underlying silicon technology are beginning to reach their limits, future computing systems must achieve significantly lower cost, lower power, higher performance/watt, and higher reliability than ever before. Supercomputing

To address these challenges, IBM Research brings together a broad set of skills: micro-architects, compiler writers, and performance experts work closely together and collaborate with experts in interconnect, memory subsystems, operating systems, and packaging. Computer architects investigate novel designs for processors, embedded cores, as well as hardwired and programmable accelerators. Memory subsystem and interconnect researchers advance "memory wall" and "I/O wall" issues. Researchers explore the design of the entire range of IBM systems, from game processors to industry-leading commercial systems and the largest supercomputers. The era of multiple cores per chip and System-on-a-Chip (SoC) provides opportunities for devising new architectural structures and approaches.

THE CELL BROADBAND ENGINE

The Cell Broadband Engine™ (Cell BE) is a multi-core architecture optimized for computer-intensive rich media applications and will provide the next generation of scalable and power-efficient microprocessors. It grew from a challenge to provide power-efficient and cost-effective high-performance processing for a wide range of applications, including demanding game consoles, such as the Sony Playstation 3. Designed as a joint project by IBM, Sony, and Toshiba, Cell BE will enable an unprecedented leap in gaming performance, thanks to the pairing of a high-performance PowerPC Processor Element (PPE) with novel Synergistic Processing Elements (SPEs) — programmable accelerators tailored to media applications. IBM Research has participated throughout the entire development of the Cell architecture, its implementation, and its software enablement.

CHIPS AND COMPILERS

Recent innovations can be found in a number of IBM offerings: POWER and PowerPC® processor chips and systems, which were the first in the industry to place multiple processing cores on a single die; zSeries®, which are today's most reliable and best virtualized systems; and the Cell BE. Leading-edge compiler technology encompasses research on the IBM proprietary XL compiler family for C, C++, and FORTRAN, as well as on Java™ compilers and the GNU Compiler Collection (GCC), resulting, for example, in automatic exploitation of parallelism for heterogeneous systems like Cell BE, and such Java advances as improved garbage collection, faster "just-in-time" compilation, and detection of problematic coding patterns in large applications.

BLUE GENE/L

Research designed and developed Blue Gene/L, now the world's fastest supercomputer. Research is currently developing versions that will far surpass Blue Gene/L in performance and power efficiency, and is also exploring how Blue Gene/L's innovative features, such as organization, interconnect, packaging, and cooling concepts, can improve the next generations of IBM systems. With sponsorship from the Defense Advanced Research Projects Agency (DARPA), Research is also playing a leading role in the Productive, Easy-to-use, Reliable Computing Systems (PERCS) project, which seeks a new generation of high-performance, programmable, portable, and robust commercial systems. A major goal of this research is to enable significantly higher productivity for application

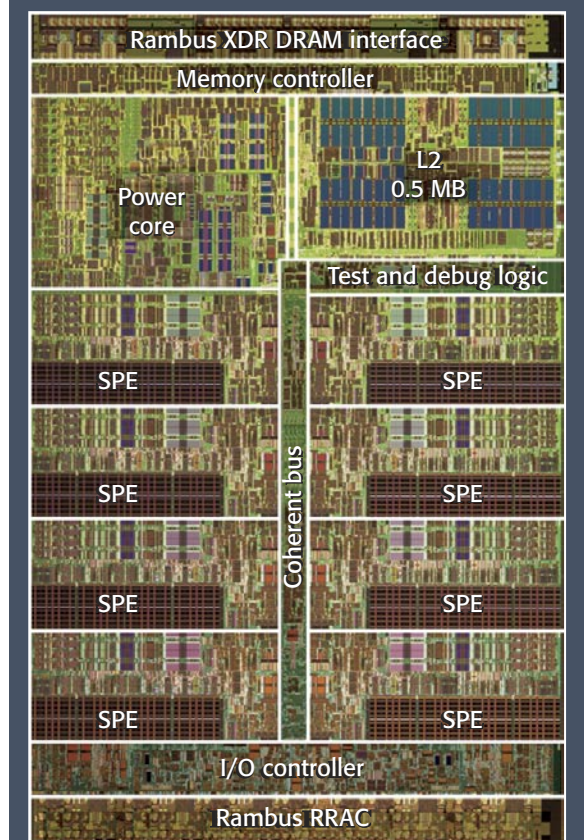
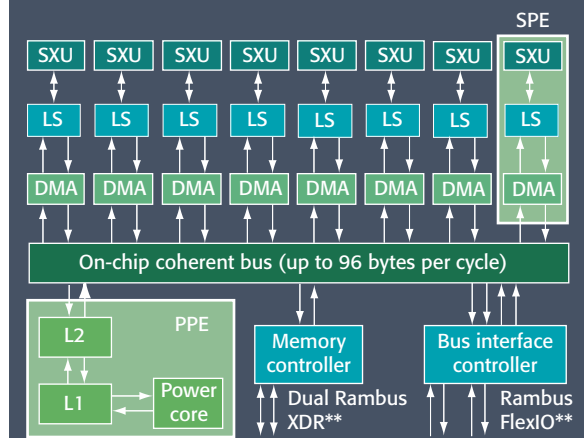

Cell Broadband Engine block diagram and die photo. (Cell die photo courtesy of Thomas Way, IBM Burlington. Figure adapted from IBM Journal of Research and Development, Volume 49, No. 4, (2005), p. 592).

Blue Gene/L

