

Dummy Fill Density Analysis with Coupling Constraints

Hua Xiang[†], Liang Deng[‡], Ruchir Puri[†], Kai-Yuan Chao[‡], Martin D.F. Wong[‡]
[†]IBM T.J. Watson, Yorktown Heights NY {huaxiang, ruchir}@us.ibm.com
[‡] ECE Department, UIUC, Urbana IL {ldeng, mdfwong}@uiuc.edu
[‡] Intel Corporation, Hillsboro OR kaiyuan.chao@intel.com

ABSTRACT

In modern VLSI manufacturing processes, dummy fills are widely used to adjust local metal density in order to improve layout uniformity and yield optimization. However, the introduction of a large amount of dummy features also affects wire electrical properties. In this paper, we propose the first Coupling constrained Dummy Fill (CDF) analysis algorithm which identifies feasible locations for dummy fills such that the fill induced coupling capacitance can be bounded within the given coupling threshold of each wire segment. The algorithm also makes efforts to maximize ground dummy fills, which are more robust and predictable. The output of the algorithm can be treated as the upper bound for dummy fill insertion, and it can be easily adopted in density models to guide dummy fill insertion without disturbing the existing design.

Category: B.7.2 [Integrated Circuits]: Design Aids - Placement and routing; J.6 [Computer Applications]: Computer-Aided Engineering - Computer-aided design

Terms: Algorithms, Design

Keywords: dummy fills, coupling, CMP

1. INTRODUCTION

In modern VLSI manufacturing processes, foundries usually require an effective metal density to be satisfied in order to achieve layout uniformity and yield optimization. Dummy fills are widely used to increase the density of sparse regions. In general, layout density control consists of two phases: density analysis and fill synthesis. Density analysis is to decide the available positions for dummy fills. Fill synthesis computes the amount of dummy features for each density window [1].

Most previous works [1, 2, 3, 4, 8, 9] focus on fill synthesis. And none of these works consider the dummy fill coupling impacts on neighboring wires. [5] formulated a performance impact limited fill approach. But their model assumes that the dummy feature width w is much smaller than the spacing between two signal wires d , i.e., $w \ll d$. Based on this assumption, they derived the capacitance formulas that are only related to the distance of two wires, and to-

tally ignore the spacing between dummy fills and wires. However, the dummy fill induced coupling capacitance is tightly related to the distance between dummy fills and wires. Furthermore, in the current technology, $w \ll d$ does not hold at all! For example, in one foundry, the width of a floating metal fill shape on a metal layer can be four and a half times of the minimum spacing of that metal level. Figure 1 shows the dummy fill impacts on wire capacitance. The simulation is based on the test structure in Figure 1 (a) in 65nm technology node. One signal wire is placed between two power rails. The dummy features, which are floating metal squares, are inserted around the signal wire. When the spacing between dummy fills and the signal wire changes, the induced wire capacitance is also different, varying from 3% to 10%. The large coupling impacts from dummy fills definitely cannot be ignored.

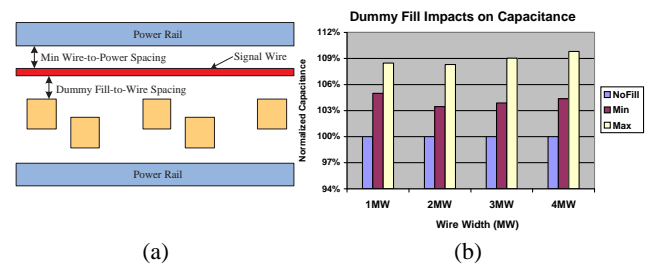

Figure 1: (a) Test structure: one signal wire is placed between two power rails. Dummy fills are inserted around the signal wire. (b) Dummy fill introduced coupling capacitance on wires with different widths. No fill is the case without dummy fills. Min/Max is the minimum/maximum capacitance increase that is introduced by dummy fills due to the different spacing between dummy fills and the signal wire. MW refers to the minimum wire width.

In this paper, we address the dummy fill density analysis problem, and propose the first Coupling constrained Dummy Fill (CDF) algorithm which identifies feasible locations for dummy fills such that the fill induced coupling capacitance can be bounded within the given coupling threshold of each wire segment. The output of our algorithm can be easily adopted in density models for fill synthesis. For example, the CMP density calculation in [1, 2, 3, 4, 8, 9] require that the upper bound of dummy fills for each window must be given. Based on a CDF solution, it is very easy to derive the maximum amount of dummy fills in each window. Furthermore, our algorithm outlines the dummy fill regions such that no coupling violations will be introduced as long as dummy fills are inserted

Permission to make digital or hard copies of all or part of this work for personal or classroom use is granted without fee provided that copies are not made or distributed for profit or commercial advantage and that copies bear this notice and the full citation on the first page. To copy otherwise, to republish, to post on servers or to redistribute to lists, requires prior specific permission and/or a fee.

ISPD'07, March 18–21, 2007, Austin, Texas, USA.

Copyright 2007 ACM 978-1-59593-613-4/07/0003 ...\$5.00.

in those regions. This allows different dummy fill patterns to be applied.

The dummy fills can either be connected to ground or be left floating. Both types are supported and adopted [11] in the industry. Overall, the coupling capacitance of floating dummy fills is less than that of ground fills. Thus we are expected to get even larger capacitance increase from ground fills. On the other hand, ground fills are more robust and predictable. They can be used for noise shielding, and avoid fill induced uncertain floating voltage. Therefore, ground dummy fills are still favored over floating dummy fills. Furthermore, ground dummy fills can help to reduce the IR-drop of the power distribution network [7]. In our algorithm, we also make efforts to maximize locations for ground fills.

For the rest of the paper, we first give the formal formulation of the CDF problem in Section 2. In Section 3, we present the CDF algorithm to identify feasible ground/floating dummy fill positions with capacitive coupling constraints. The algorithm first locates dummy fill regions using ILP formulations. Then it calculates the maximum ground dummy fills that can be inserted. The exact ground/floating fill locations are determined by a dynamic programming based algorithm that maximizes the total amount of floating dummy fills as well. The experimental results are presented in Section 4, and Section 5 concludes the paper.

2. PROBLEM FORMULATION

The dummy fills are metal tiles, and they are to be inserted in the empty space among signal wires. Since ground dummy fills need connection to power grids on upper/lower layers, their width and pitch are usually larger than those of the floating dummy fills. Assume the half width of a ground fill is w_g and the spacing between two ground fills is s_g . Let w_f and s_f be the half width and spacing of floating dummy fills, respectively. The spacing between a ground dummy fill and a floating dummy fill is also s_g .

Given a routing solution R on layer L , there are N signal wire segments S_1, \dots, S_N . For each wire segment S_i , it has a coupling threshold C_i . The dummy fills are inserted in the empty space with the following constraints:

1. The spacing between a dummy feature and a signal wire must be larger than the min-spacing requirement s .
2. The spacing between two dummy features (ground or floating) should satisfy the given spacing requirements.
3. If the total capacitive coupling on S_i after inserting dummy fills is c_i , then $c_i \leq C_i$.

Our target is to identify as many as possible feasible positions for ground dummy fills. At the same time, maximize floating fill insertion as well.

Figure 2 shows an example. In this example, there are 5 wire segments S_1, S_2, S_3, S_4 , and S_5 . d_{g1} and d_{g2} are ground fills, while d_{fi} ($i = 1, \dots, 9$) are floating fills. Since S_1 has a tight coupling bound, dummy fills have to be placed far from S_1 . The power rail pair is on the lower layer. For d_{g1} and d_{g2} , they can be connected to G_{nd} . Therefore, they are inserted as ground fills. Although d_{f7} is long enough to cross the power rail pair, the allowable spacing between S_4 and S_5 is not enough to hold a ground fill. Still a floating fill is inserted.

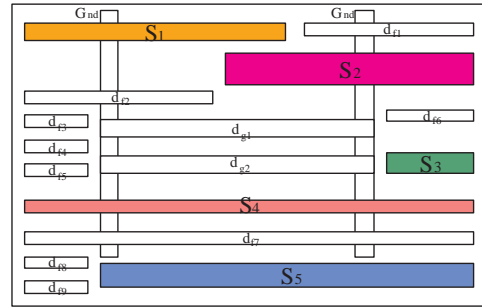

Figure 2: A dummy fill solution for a CDF problem.

3. CDF ALGORITHM

The whole flow of the CDF algorithm can be summarized as follows.

Algorithm CDF

1. Build the coupling capacitance lookup table;
2. Slice the layout into slots;
3. Identify dummy fill regions for each slot;
4. Determine ground/floating fill locations;

The output is the feasible locations for ground/floating dummy fills satisfying the coupling constraints. It can be treated as the upper bound for fill synthesis with the guarantee that no coupling violations will be introduced as long as dummy fills are placed on these locations. Without loss of generality, we assume that all wire segments are horizontal, and dummy fills are horizontal metal tiles as well.

3.1 Coupling Capacitance Lookup Table

In general, each segment has the coupling effect on all other segments. However, the coupling capacitance decreases dramatically if the segment is out of the neighborhood of the other segment [10, 12]. Therefore, we only consider the capacitive coupling between two neighboring parallel wires and suppose the neighborhood distance is D . Then the capacitive coupling between two segments can be expressed in the following formula:

$$c = \begin{cases} \alpha \cdot \frac{L}{d^\beta} & d \leq D \\ 0 & d > D \end{cases}$$

where α is the coupling parameter, β is an experimentally estimated constant [10], L is the coupling length, and d is the distance between two segments.

Although the behavior of floating dummy fills is less predictable, the above formula can totally bound their coupling impacts. Therefore, we apply this model for all coupling calculations.

To speed up execution, we build up a lookup table. For each entry, it records the distance of two wires and the corresponding unit length coupling capacitance. Then the coupling between two wires can be calculated in constant time.

3.2 Slot Partition

Since the coupling capacitance is closely related to the coupling length between two wires, we first slice the whole layout vertically according to x coordinates of the end points of each wire segment. As shown in Figure 3, the layout is partitioned into 5 slots. For each slot, the wire distribution may be different, and it directly affects

dummy fill insertion. Therefore, our dummy fill insertion strategy is to insert dummies slot by slot. This slicing step can be easily achieved by sorting x coordinates of all end points, and the running time is bounded by $O(N \log N)$.

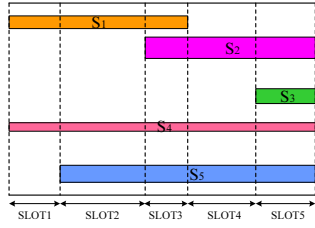

Figure 3: The illustration of layout slicing.

Once the layout is partitioned into slots, the capacitive coupling threshold of each wire segment is redistributed according to its length in each slot, i.e., if the length of wire segment S_i is L_i , and the slot length is L'_i , then the capacitive coupling threshold of S_i in the given slot is $C_i * (L'_i/L_i)$. Without confusion, we still use C_i to represent the coupling threshold of S_i in the given slot.

For some positions, we know clearly whether dummy fills can be inserted or not. Therefore, we can further partition the slot into smaller pieces, and solve the dummy fill insertion problem for each slot piece independently. Since the dummy fill insertion in each slot piece has no impact on other slot pieces, the quality of the final fill solution is guaranteed.

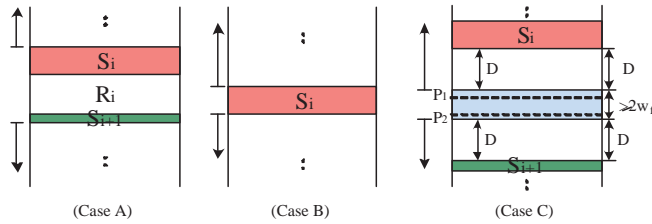

Figure 4: Three cases for slot partition

There are three cases as shown in Figure 4.

Case A: There is no feasible position between two wires S_i and S_{i+1} , i.e., the spacing between S_i and S_{i+1} is less than $2 \cdot w_f + 2 \cdot s$. Then no dummy fills can be inserted between S_i and S_{i+1} . Therefore, the dummy fill insertion above S_i has no impacts on the fill solution below S_{i+1} . We can safely divide the slot into two parts: a slot piece above S_i and a slot piece below S_{i+1} .

Case B: If there is no coupling constraint on S_i , then dummy fills can be inserted around S_i as long as the min-spacing requirement is satisfied. Therefore, we can apply the dummy fill insertion algorithm for the slot piece above S_i and the slot piece below S_i separately.

Case C: If the spacing between S_i and S_{i+1} is larger than $2 \cdot D + 2 \cdot w_f$, then at least one dummy fill can be inserted. As shown in Figure 4 (Case C), the middle cyan region can hold at least one dummy fill. The spacing between P_1 and S_i is D , and the spacing between P_2 and S_{i+1} is also D . If $|P_1 - P_2| \geq w_f$,

the piece between P_1 and P_2 is safe for dummy insertion, and the dummy fill insertion above P_1 is independent of the fill insertion below P_2 . Therefore, we only need to process two slot pieces: the piece above P_1 and the piece below P_2 .

Combining these three cases, we can cut a slot into smaller pieces, and identify dummy fill regions for each slot piece separately. For high density region, Case A helps to slice a slot into smaller pieces; for low density region, Case C can be applied. These three cases help to control the number of wires in each slot piece within a reasonable range. This greatly reduces the problem size and speeds up the execution. For convenience, we also refer a slot piece as a slot since the dummy fill algorithm is applied on each slot piece independently.

3.3 Dummy Fill Region Identification

In this section, we identify dummy fill regions for the given slot subject to the coupling capacitance constraints. We first partition the slot into FillRegions which covers all possible positions for the dummy insertion. Then an optimal ILP based algorithm is proposed to maximize effective dummy fill regions assuming that each FillRegion has at least one dummy fill assigned. Next, we extend the algorithm to allow no fills in some FillRegions.

3.3.1 FillRegion

Suppose there are m wire segments S_1, \dots, S_m in the given slot. The slot width is L . For each wire segment S_i , let y_i be the y coordinate of the center line, w_i be the half width of the segment, and C_i be the coupling threshold. Also define $d_i = \sqrt[3]{\alpha L / C_i}$, which specifies the minimum spacing between the dummy fills and S_i respect to the given coupling threshold.

For convenience, we let the region between two wire segments S_i and S_{i+1} ($i = 1, \dots, m-1$) be R_i . The region above S_1 is R_0 , and R_m is the region below S_m . For each region R_i ($i = 1, \dots, m-1$), its **FillRegion** is defined as $[V_i, U_i] = [y_{i+1} + w_{i+1} + w_f + \max\{d_{i+1}, s\}, y_i - w_i - w_f - \max\{d_i, s\}]$ since the spacing between a dummy fill and a wire segment must satisfy both coupling constraint and min-spacing constraint. So the FillRegion size is $r_i = U_i - V_i + 1$. This bound covers all feasible locations for dummy fills, but not all positions are valid to insert dummies due to the coupling constraints. Similar rules apply for R_0 and R_m . For convenience, we also refer R_i to the FillRegion of R_i .

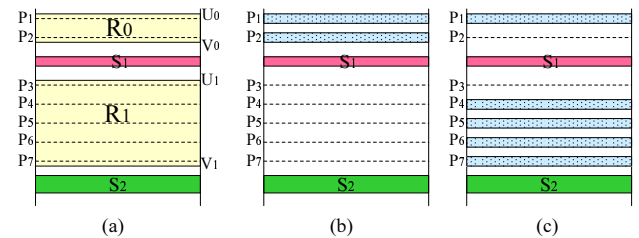

Figure 5: (a) The slot piece includes two wire segments S_1 and S_2 . In R_0 , two dummy fills can be inserted as denoted by P_1 and P_2 , and R_1 can hold five dummy fills. (b) When two dummy features are inserted in R_0 , no fills can be placed in R_1 since the coupling between P_2 and S_1 has reached the coupling threshold of S_1 . (c) Only P_1 is used for dummy insertion in R_0 . 4 dummy fills can be inserted in R_1 .

If we arbitrarily assign dummy fills into the FillRegions, the

amount of inserted fills may be limited. Figure 5 gives an example. In Figure 5 (a), there are two signal wire segments S_1 and S_2 . In R_0 , two dummy fills can be inserted as denoted by P_1 and P_2 . R_1 can hold five dummy features. If two dummy features are inserted in R_0 as shown in Figure 5 (b), they consume all the coupling budget of S_1 , and no dummies can be inserted within R_1 . On the other hand, if only one dummy is inserted in R_0 as shown in Figure 5 (c), four dummy fills can be placed in R_1 . Therefore, three more dummies can be inserted than the solution in Figure 5 (b).

3.3.2 Optimal Dummy Fill Region Generation

In this section, we present an optimal algorithm to maximize the total effective regions for dummy fill insertion. The algorithm identifies dummy fill regions from FillRegions such that no capacitive coupling violations are introduced if dummy fills are inserted in those regions. At the same time, the total dummy fill regions are maximized. The algorithm is based on the ILP formulation. We assume that at least one dummy feature is to be inserted in each FillRegion. In the next section, we will extend our ILP formulation to allow no-fills in some FillRegions.

For each wire segment S_i ($i = 1, \dots, m$), two sets of variables X_i and Y_i are created: $X_i = \{x_{i1}, \dots, x_{ir_{i-1}}\}$ and $Y_i = \{y_{i1}, y_{i2}, \dots, y_{ir_i}\}$. The values of x_{ij} and y_{ik} are either 0 or 1. To facilitate expression, two auxiliary variables T_i and B_i are used for each S_i . The following is the ILP formulation to identify maximum dummy fill regions.

$$\min \{T_1 + \sum_{i=1}^{m-1} (B_i + T_{i+1}) + B_m\}$$

subject to:

$$x_{i1} + \dots + x_{ir_{i-1}} = 1; \quad i \in [1, m] \quad (1)$$

$$y_{i1} + \dots + y_{ir_i} = 1; \quad i \in [1, m] \quad (2)$$

$$T_i = 1 \cdot x_{i1} + 2 \cdot x_{i2} + \dots + r_{i-1} \cdot x_{ir_{i-1}} - 1; \quad i \in [1, m] \quad (3)$$

$$B_i = 1 \cdot y_{i1} + 2 \cdot y_{i2} + \dots + r_i \cdot y_{ir_i} - 1; \quad i \in [1, m] \quad (4)$$

$$B_{i-1} + T_i < r_{i-1}; \quad i \in [2, m] \quad (5)$$

$$\sum_{j=1}^{r_{i-1}} p_{ij} \cdot x_{ij} + \sum_{k=1}^{r_i} q_{ik} \cdot y_{ik} \leq C_i + c_i^{j-1} + c_i^{k+1}; \quad i \in [1, m] \quad (6)$$

$$x_{ij} = 0, 1; \quad i \in [1, m]; \quad j \in [1, r_{i-1}];$$

$$y_{ik} = 0, 1; \quad i \in [1, m]; \quad k \in [1, r_i];$$

x_{ij} refers to the j^{th} position above S_i , and y_{ik} represents the k^{th} position below S_i . If $x_{ij} = 1$, it means that the j^{th} position and its above positions are selected. Therefore, only one value of x_{ij} can be 1. Equation (1) expresses this constraint. Similarly, if $y_{ik} = 1$, it means the k^{th} position and positions below it are selected. Still only one value of y_{ik} can be 1, and Equation (2) is used to bound the constraint.

T_i means how many positions from the bottom of R_{i-1} are not used, and B_{i-1} means how many positions from the top of R_{i-1} are not used. Therefore, the total number of unused positions should be less than the total positions in the region R_{i-1} . This constraint is expressed by Equation (5).

Finally, Equation (6) describes the coupling constraint on each wire segment. The capacitive coupling between any two given positions can be easily derived from the lookup table. Let c_i^{j-1} ($i = 2, \dots, m$) be the coupling capacitance between S_i and S_{i-1} . For convenience, set $c_1^0 = 0$. Similarly, c_i^{k+1} ($i = 1, \dots, m-1$) is the capacitive coupling between S_i and S_{i+1} , and $c_m^{m+1} = 0$. Also let p_{ij} be the coupling capacitance between x_{ij} and S_i , and q_{ik} be the coupling capacitance between y_{ik} and S_i . $\sum_{j=1}^{r_{i-1}} p_{ij} \cdot x_{ij}$ is the coupling capacitance between S_i and the dummy fill right above it; $\sum_{k=1}^{r_i} q_{ik} \cdot y_{ik}$

is the coupling capacitance between S_i and the dummy fill right below it. Due to the dummy fill insertion, the capacitive coupling between (S_i, S_{i-1}) and (S_i, S_{i+1}) is blocked, and the total coupling on S_i is adjusted accordingly.

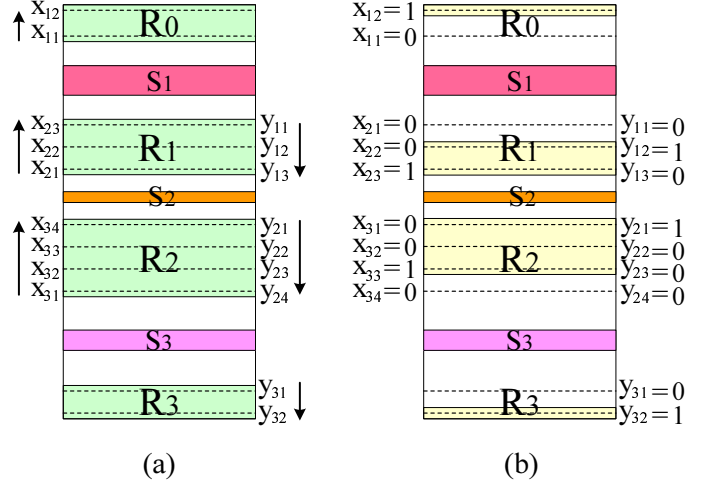

Figure 6: (a) The slot includes three wire segments S_1 , S_2 , and S_3 . For each position in the FillRegion, it is associated with variables x_{ij} and/or y_{ik} . (b) A dummy fill solution from an ILP solution with $x_{12} = x_{23} = x_{33} = 1$ and $y_{12} = y_{21} = y_{32} = 1$.

Obviously, our target is to maximize dummy fill regions, i.e., to minimize the number of unused positions, which is expressed as the sum of T_i and B_i .

Figure 6 shows an example with three wire segments S_1 , S_2 and S_3 . The green areas are the FillRegions. For each position in the FillRegions, it is associated with x_{ij} and/or y_{ik} accordingly as shown in Figure 6 (a). Figure 6 (b) gives the dummy fill region solution when $x_{12} = x_{23} = x_{33} = 1$ and $y_{12} = y_{21} = y_{32} = 1$.

3.3.3 General Dummy Fill Region Generation

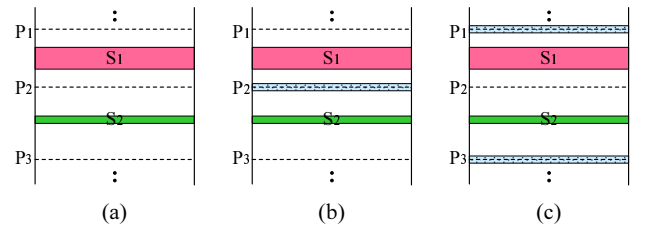

Figure 7: (a) P_1 , P_2 and P_3 are feasible positions to insert dummies. (b) When a dummy is inserted on P_2 , the introduced coupling capacitance on both S_1 and S_2 reaches the coupling thresholds of S_1 and S_2 . No dummies can be inserted on P_1 and P_3 . (c) Two dummies can be inserted on P_1 and P_3 when P_2 is left empty.

In the above section, we assume that each FillRegion has at least one dummy inserted. However, in order to maintain coupling constraints and maximize the amount of inserted dummies, not all FillRegions can get one dummy assigned. Figure 7 shows an example. In Figure 7 (a), there is one feasible position P_2 between S_1 and S_2 . If one dummy is inserted on P_2 as shown in Figure 7 (b), it

consumes the coupling budget of both S_1 and S_2 , and no fills can be placed on P_1 and P_3 . On the other hand, two dummies can be placed on P_1 and P_3 when P_2 is not used as illustrated in Figure 7 (c). Therefore, we can insert one more dummy in Figure 7 (c).

On the other hand, even density distribution is strongly preferred for yield improvement and design overhead reduction. If there is a FillRegion between two wires, it means that the spacing between two wires is large and it is desirable to insert dummies for density uniformity. Therefore, we introduce a no-fill weight λ . If a FillRegion has no fills inserted, we add a penalty in the objective function to discourage the large empty space between two wires. This helps to balance the two requests of maintaining coupling constraints and maximizing dummy fills.

Based on the ILP formulation in the previous section, we add two more variables x_{i0} and y_{i0} for each S_i . When $x_{i0} = 1$, it means no fills are inserted in the region R_{i-1} . When $y_{i0} = 1$, it means no fills are inserted in R_i . Then we extend the previous ILP formulation for the general dummy fill region generation.

$$\min \{ [T_1 + \sum_{i=1}^{m-1} (B_i + T_{i+1}) + B_m] + \lambda \cdot (y_{m0} + \sum_{i=1}^m x_{i0}) \}$$

subject to:

$$x_{i0} + x_{i1} + \dots + x_{ir_{i-1}} = 1; \quad i \in [1, m] \quad (1)$$

$$y_{i0} + y_{i1} + \dots + y_{ir_i} = 1; \quad i \in [1, m] \quad (2)$$

$$T_i = 1 \cdot x_{i1} + 2 \cdot x_{i2} + \dots + r_{i-1} \cdot x_{ir_{i-1}} - 1; \quad i \in [1, m] \quad (3)$$

$$B_i = 1 \cdot y_{i1} + 2 \cdot y_{i2} + \dots + r_i \cdot y_{ir_i} - 1; \quad i \in [1, m] \quad (4)$$

$$B_{i-1} + T_i < r_{i-1}; \quad i \in [2, m] \quad (5)$$

$$\sum_{j=1}^{r_i-1} p_{ij} \cdot x_{ij} + \sum_{k=1}^{r_i} q_{ik} \cdot y_{ik} \leq (1 - x_{i0}) \cdot c_i^{i-1} + (1 - y_{i0}) \cdot c_i^{i+1} + C_i; \quad i \in [1, m] \quad (6)$$

$$y_{(i-1)0} + x_{i1} + \dots + x_{ir_{i-1}} = 1; \quad i \in [2, m] \quad (7)$$

$$x_{(i+1)0} + y_{i1} + \dots + y_{ir_i} = 1; \quad i \in [1, m-1] \quad (8)$$

$$\begin{aligned} x_{ij} &= 0, 1; & i &\in [1, m]; & j &\in [0, r_{i-1}] \\ y_{ik} &= 0, 1; & i &\in [1, m]; & k &\in [0, r_i] \end{aligned}$$

Compared to the ILP formulation in the previous section, $\lambda \cdot (y_{m0} + \sum_{i=1}^m x_{i0})$ are added in the objective function to penalize the FillRegions without dummy fills. In Equations (1) and (2), x_{i0} and y_{i0} are added, respectively, so that both cases (with-fills and without-fills) are covered. Equations (3), (4) and (5) are not changed. Equation (6) is adjusted to include the situation such that no fills are inserted in the FillRegions above/below S_i . Meanwhile, if the FillRegion R_i has no fills, both $x_{(i+1)0}$ and y_{i0} should be 1. Therefore, two more equations (7) and (8) are used to force $x_{(i+1)0}$ and y_{i0} to be 1 at the same time. This ILP formulation accurately describes the coupling constraints and can produce dummy fill region solutions that balance both the maximum fills and the density uniformity.

3.4 Dummy Fill Insertion

Once we identify the dummy fill regions, we need specify the exact dummy fill locations. Furthermore, for each dummy fill region, they can be used for either floating fills or ground fills. Since ground fills are favored over floating fills for their reliability and predictability, we should insert as many ground fills as possible. In this section, we first calculate the maximum amount of the ground fills that can be inserted in the dummy fill regions. Then we propose a dynamic programming based algorithm to decide the positions for both ground fills and floating fills. The algorithm also maximizes the insertion of floating dummy fills.

3.4.1 Ground Dummy Fill Estimation

Ground dummies usually have a larger width and spacing, and they must connect to power rails. Figure 8 (a) shows an example with 4 slots. The regions F_i ($i = 1, \dots, 9$) are the dummy fill regions obtained by our dummy fill region generation algorithms. SLOT2, SLOT3 and SLOT4 cover a pair of $Gnds$. As illustrated in Figure 8 (b), two ground fills d_{g1} and d_{g2} are inserted going through F_3 , F_5 and F_8 . Although d_{f5} can reach both two $Gnds$, the width of F_4 , F_6 and F_9 is not enough to hold one ground fill. For the rest of the dummy fill areas, they are used for floating dummy fills (d_{f1}, \dots, d_{f8}).

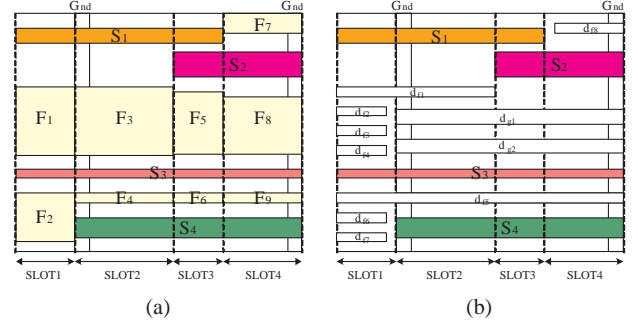

Figure 8: (a) F_1, \dots, F_9 are dummy fill regions obtained from the ILP dummy fill region generation algorithm. (b) Dummy fill solution with floating fills and ground fills.

For each position in the region outlined by a pair of power rails, if it is fully covered by dummy fill regions, the position is feasible for ground fill insertion. As shown in Figure 9 (a), there are six dummy fill regions within two $Gnds$. Two regions G_1 and G_2 can be used for ground fills.

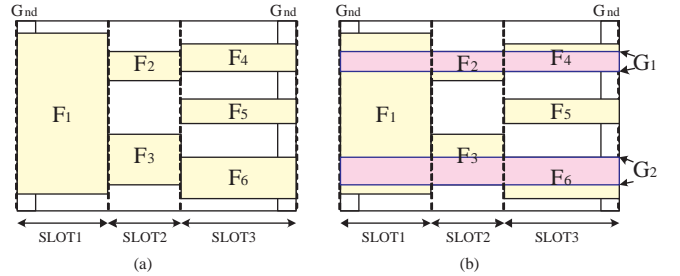

Figure 9: (a) There are 6 dummy fill regions between two $Gnds$. (b) G_1 and G_2 can be used for ground fill insertion.

For each ground fill region, suppose its height is H_g ($H_g \geq 2 \cdot w_g$). Then the maximum number of ground fills in this region is $\lceil (H_g - 2 \cdot w_g) / (2 \cdot w_g + s_g) \rceil + 1$.

Although the number of ground fills can be determined very easily, the exact locations of ground fills have large impacts on floating fills. Figure 10 shows an example. In Figure 10 (a), the region outlined by blue lines can insert two ground fills. If the ground fills are placed as Figure 10 (b), no floating fills can be inserted in F_1 . On the other hand, if the two ground fills are placed as Figure 10 (c), d_{f1} can be inserted.

This tells us that the ground fill locations have large impacts

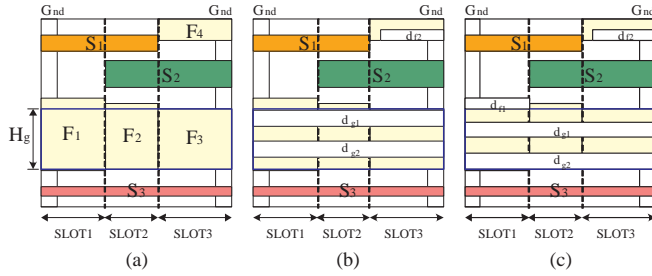

Figure 10: (a) Two ground fills can be inserted in the region outlined by blue lines. (b) No floating fills can be inserted in F_1 . (c) A floating fill d_{f1} can be placed in F_1 .

on floating fill assignment. Therefore, we propose the following dynamic programming based algorithm to determine dummy fill positions so that the number of floating fills can be maximized as well.

3.4.2 Dummy Fill Position Calculation

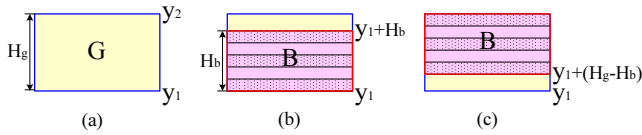

Figure 11: (a) G is a ground fill region with a height H_g . (b) B represents the area occupied by ground fills. (c) The bottom edge of region B in G .

If the ground fills are packed tightly, i.e., the ground fills are placed with minimum ground fill spacing s_g , then more room is left for floating fills. Therefore, we group the ground fills together, and treat them as a whole. In Figure 11 (a), G represents a ground fill region with a height H_g . y_1 and y_2 are the y coordinates of the bottom and upper edges of G , respectively. Suppose the number of ground fills inserted in G is N_g , and let B represent the total area occupied by ground fills. The height of B is $H_b = (N_g - 1) \cdot (2 \cdot w_g + s_g) + 2 \cdot w_g$. Therefore, the y coordinate of the bottom edge of B varies within the range $T = [y_1, y_1 + (H_g - H_b)]$ as illustrated in Figure 11 (b) and (c). Obviously, $H_g - H_b < 2 \cdot w_g + s_g$. If the position of B is fixed, then we can calculate how many floating fills can be inserted. This motivates us for the following dynamic programming based dummy fill insertion algorithm.

FP (Fill Position) Problem Between a pair of G nds, there are n dummy fill regions F_1, \dots, F_n , and m ground fills regions G_1, \dots, G_m . Assume the ground fills occupy a region B_i in G_i . Suppose the height of G_i is H_{gi} , and its y coordinate of the bottom edge is y_{gi} . The height of B_i is H_{bi} , and its y coordinate of the bottom edge is y_{bi} . The target is to determine the values of y_{bi} so as to maximize the number of floating dummy fills.

Without loss of generality, suppose the y coordinate of the whole region is $[0, Y]$. Also let $T_i = [y_{gi}, y_{gi} + (H_{gi} - H_{bi})]$, which specifies all the possible positions of the bottom edge of B_i .

Our approach is to scan the ground fill regions from bottom to top (i.e., from G_1 to G_m). For each position in T_i , we calculate the maximum floating fills that can be inserted below it, and record the values in a two-dimension array Rec . We also use another two-

dimension array Pre for tracing purpose. After processing G_m , we can get the maximum number of floating fills. Once the positions of ground fills are settled, the floating fill positions can be determined easily.

Algorithm Fill_Position

1. Initialize Rec and Pre ;
2. For each position p in T_1
3. $Rec[1][p] =$ number of floating fills within $[0, p - s_g]$;
- 4.
5. For $i = 2$ to m
6. For each position p in T_i
7. For each position q in T_{i-1}
8. fills = number of floating fills
9. within $[q + H_{b(i-1)} + s_g, p - s_g]$;
9. if (fills + $Rec[i-1][q] > Rec[i][p]$)
10. then $Rec[i][p] =$ fills + $Rec[i-1][q]$;
11. $Pre[i][p] = q$;
- 12.
13. maxfills = 0;
14. For each position p in T_m
15. fills = number of floating fills within $[p + H_{bi} + s_g, Y]$;
16. if (maxfills < fills + $Rec[m][p]$)
17. then maxfills = fills + $Rec[m][p]$;
18. maxpre = p;

In the FP algorithm, we need to calculate the number of floating fills in the given range $[Q, P]$. So we need to check each F_i . If F_i have no intersection with $[Q, P]$, then no floating fills will be inserted in $[Q, P]$ from F_i . Otherwise, we have four cases as shown in Figure 12. Suppose the y coordinates of the bottom and upper edges of F_i are y_{1i} and y_{2i} , respectively.

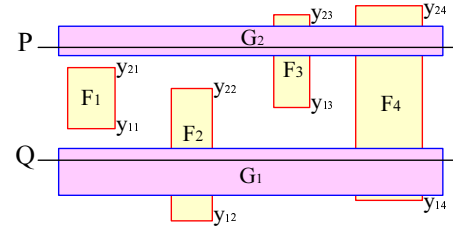

Figure 12: Four cases for floating dummy fill calculation

Case 1: The whole dummy fill region F_i is within $[Q, P]$, i.e., $Q \leq y_{1i}$ and $y_{2i} \leq P$. If $y_{2i} - y_{1i} \geq 2 \cdot w_f$, then the total number of floating fills in F_i is $\lceil (y_{2i} - y_{1i} - 2 \cdot w_f) / (2 \cdot w_f + s_f) \rceil + 1$. Otherwise, no fills can be inserted. One example is F_1 in Figure 12. For F_1 , $Q < y_{11}$ and $y_{21} < P$, and the floating fill insertion in F_1 is totally determined by y_{11} and y_{21} .

Case 2: The dummy fill region F_i is partially within $[Q, P]$ such that $y_{1i} \leq Q$ and $Q \leq y_{2i} \leq P$. If $y_{2i} - Q \geq 2 \cdot w_f$, then the total number of floating fills in F_i is $\lceil (y_{2i} - Q - 2 \cdot w_f) / (2 \cdot w_f + s_f) \rceil + 1$. Otherwise, no fills can be inserted. F_2 in Figure 12 gives an example.

Case 3: Similar to Case 2. The dummy fill region F_i is partially within $[Q, P]$ with $Q \leq y_{1i} \leq P$ and $P \leq y_{2i}$. If $P - y_{1i} \geq 2 \cdot w_f$, then the total number of floating fills in F_i is $\lceil (P - y_{1i} - 2 \cdot w_f) / (2 \cdot w_f + s_f) \rceil + 1$. Otherwise, no fills can be inserted. F_3 in Figure 12 shows an example.

Table 1: Test Results

File	Layout Area(um^2)	Wire Segs	Wire Cons.	Orignal MaxDens	CPU Time	Violations		Max-Density			Ave-Density		
						NoCap	CDF	NoCap	CDF	Diff	NoCap	CDF	Diff
Test1	483.8x441.4	1405	1079	12.95%	1s	563	0	49.74%	49.74%	0.00%	44.81%	39.85%	4.96%
Test2	4654.0x4660.4	6370	4437	23.36%	2s	2209	0	50.37%	50.01%	0.36%	48.41%	47.46%	0.95%
Test3	438.2x437.4	8670	5694	11.73%	2s	4528	0	49.18%	49.14%	0.04%	42.99%	37.63%	5.36%
Test4	4660.4x4682.8	17594	12241	23.06%	9s	6033	0	50.14%	50.13%	0.01%	47.99%	46.27%	1.72%
Test5	1478.0x1497.2	29936	21953	24.25%	10s	13988	0	50.37%	49.68%	0.69%	45.87%	37.03%	8.84%
Test6	7548.8x7467.2	44078	32378	24.61%	40s	6257	0	51.49%	50.26%	1.23%	48.10%	45.99%	2.11%
Test7	1479.5x1497.0	53082	31569	19.89%	12s	22355	0	50.09%	50.09%	0.00%	46.73%	44.89%	1.84%
Test8	4683.8x4683.4	58169	42889	23.86%	108s	25229	0	50.47%	49.74%	0.67%	47.94%	40.95%	6.99%
Test9	7477.2x7550.4	119490	84971	24.72%	209s	30529	0	53.36%	51.16%	2.20%	49.11%	44.53%	4.58%

Case 4: The dummy fill region F_i fully covers $[Q, P]$, i.e., $y_{1i} \leq Q$ and $P \leq y_{2i}$. If $P - Q \geq 2 \cdot w_f$, then the total number of floating fills in F_i is $\lceil (P - Q - 2 \cdot w_f) / (2 \cdot w_f + s_f) \rceil + 1$. Otherwise, no fills can be inserted. F_4 in Figure 12 is an example.

For each F_i , the number of floating fills can be calculated in constant time. In the FP algorithm, $T_i < 2 \cdot w_g + s_g$. Therefore, the total running time of FP algorithm can be bounded by $O(m \cdot n \cdot T^2)$, where $T = 2 \cdot w_g + s_g$.

4. EXPERIMENTAL RESULTS

Our algorithm was implemented in C on a linux workstation (2.3GHz). We use GLPK (GNU Linear Programming Kit) as our ILP solver. The test cases are derived from the industry designs and the coupling thresholds are generated randomly. Set the dummy fill spacing be the same as the fill width, i.e., $2 \cdot w_f = s_f$ and $2 \cdot w_g = s_g$. The density window size is set as $24um$. Table 1 shows the results of the nine test cases. ‘‘Wire Segs’’ is the total number of wire segments in each test case. ‘‘Wire Cons.’’ is the number of wires with coupling constraints. ‘‘Original MaxDens’’ is the maximum density of all the density windows before fill insertion. For all the test cases, the CDF algorithm can find feasible positions for dummy fills within a short time. We compared our results with the filling results without considering coupling constraints. For ‘‘NoCap’’, dummy fills are inserted in the empty space as long as they satisfy the spacing rules. Using our algorithm, the maximum density of the final postfill layouts is around 50% for all the test cases. Compared with NoCap, the final maximum density and average density are pretty close, which means that our algorithm can identify feasible fill locations very effeciently. A small density gap (both maximum density and average density) between CDF and NoCap exists. This is caused by wire patterns and coupling constraints. However, as shown in NoCap, when the coupling constraints are not considered during dummy fill insertions, the dummy fill induced coupling may make the total coupling on wires exceed the given threshold. As shown in Table 1, ‘‘Violations’’ is the number of wires whose total capacitive coupling is larger than the given threshold. For all the test cases, if the dummy fills are inserted regardless the coupling constraints, a large number of wires have coupling violations.

5. CONCLUSION

In this paper, we present the first dummy fill density analysis algorithm which takes coupling impacts into consideration. The algorithm also makes efforts to maximize ground dummy fills, which

are more robust and predictable. The output of the algorithm can be treated as the upper limit of dummy fill insertion, and it can be easily adopted in density models to guide dummy fill insertion without disturbing the existing design. Furthermore, our algorithm outlines the dummy fill regions such that no coupling violations will be introduced if dummy fills are inserted in those regions. This allows different dummy fill patterns to be applied.

6. REFERENCES

- [1] Y. Chen, A. B. Kahng, G. Robins and A. Zelikovsky, Practical Iterated Fill Synthesis for CMP Uniformity, Proc. of Design Automation Conf., pp. 671-674, June 2000.
- [2] Y. Chen, A. B. Kahng, G. Robins and A. Zelikovsky, Hierarchical Dummy Fill for Process Uniformity, Proc. Asia and South Pacific Design Automation Conf., pp. 139-144, Jan. 2001.
- [3] Y. Chen, A. B. Kahng, G. Robins and A. Zelikovsky, Closing the Smoothness and Uniformity Gap in Area Fill Synthesis, Proc. ACM/IEEE Intl. Symp. on Physical Design, pp. 137-142, April 2002.
- [4] Y. Chen, A. B. Kahng, G. Robins, A. Zelikovsky, and Y. H. Zheng, Data Volume Reduction in Dummy Fill Generation, Proc. Design Automation and Testing in Europe, pp. 868-873, March 2003.
- [5] Y. Chen, P. Gupta, and A. B. Kahng, Performance-Impact Limited Area Fill Synthesis, Proc. of Design Automation Conf., pp. 22-27, June 2003.
- [6] L. He, A. B. Kahng, K. H. Tam and J. Xiong, Design of Integrated-Circuit Interconnects with Accurate Modeling of Chemical-Mechanical Planarization, Proc. of SPIE Vol. 5756, Bellingham, WA, 2005.
- [7] K. S. Leung, SPIDER: Simultaneous Post-Layout IR-Drop and Metal Density Enhancement with Redundant Fill, Proc. of ICCAD, pp. 33-38, San Jose, CA, 2005.
- [8] R. Tian, X. Tang, and D. F. Wong, Dummy Feature Placement for Chemical-Mechanical Polishing Uniformity in a Shallow Trench Isolation Process, Proc. International Symposium on Physical Design, pp 118-123, 2001.
- [9] R. Tian, D. F. Wong, and R. Boone, Model-based Dummy Feature Placement for Oxide Chemical-Mechanical Polishing Manufacturability, Proc. Design Automation Conf, pp 667-670, 2000.
- [10] T. Sakurai and k. Tamaru. Simple Formulas for Two and Three Dimensional Capacitance, IEEE Trans. Electron Devices, 1983.
- [11] B. E. Stine, D. S. Boning, J. E. Chung, L. Camilletti, F. Kruppa, E. R. Equi, W. Loh, S. Prasad, M. Muthukrishnan, D. Towery, M. Berman, and A. Kapoor, The physical and electrical effects of metal-fill patterning practices for oxide chemical-mechanical polishing processes. IEEE Trans. on Electron Devices, 45(3), pp. 665-679, 1998.
- [12] H. Zhou and M. D. F. Wong, Global Routing with Crosstalk Constraints, ACM/IEEE DAC, San Francisco, CA, 1998.